

REV.	REVISED DESCRIPTION	DATE	CHECKED
A0	FIRST RELEASE	2019/11/23	

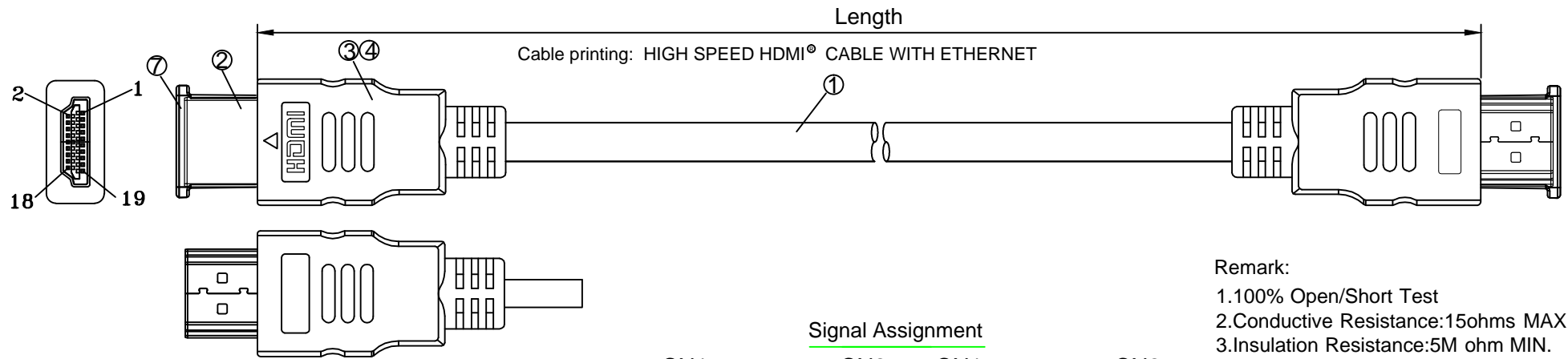

Remark:
 1.100% Open/Short Test
 2.Conductive Resistance:15ohms MAX
 3.Insulation Resistance:5M ohm MIN.
 4.HI-POT:DC 300V/10MS.
 5.The product is Reach/RoHS 2.0 compliant.
 6.Support 4K*2K@60Hz

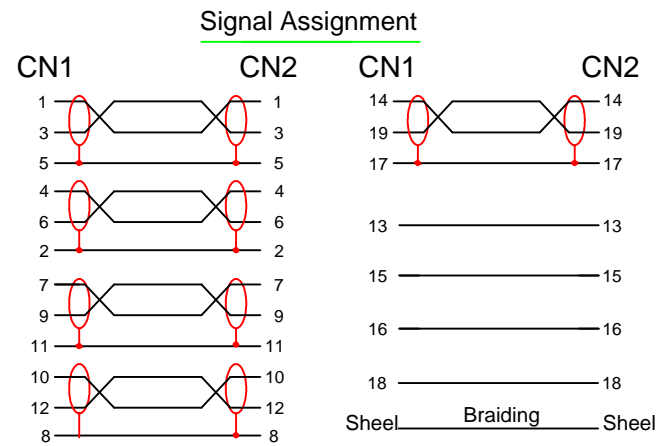
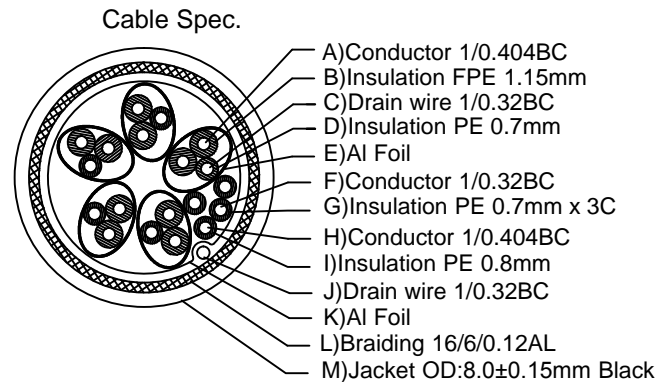

Item NO.	Length
K5431SW.10	10.0m
K5431SW.15	15.0m

ITEM	DESCRIPTIONS & SPECIFICATIONS	QTY	REMARK
⑤	HDMI Protective Cap, PE	2PCS	
④	External Mold Outer Mould 45P PVC, Black	2PCS	
③	Inernal Mold Inner Mould PE	2PCS	
②	Connector HDMI A PLUG PIN, Gold-Plated	2PCS	
①	Cable 26+28+26AWG 2.0V (19+1BC) 96ALB HDMI Cable OD:8.0mm (0.404BC+FPE)*1P+D+AL] *5C + (0.32BC+HDPE)*3C + (0.404BC+HDPE)*1C + AL + D + 96ALB PVCOD8.0mm		

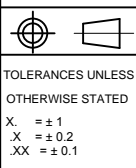

ERP NO.:		SAMPLE DWG NO.:	
DOC No.:		REVISION	A0
CUSTOMER:		UNIT	mm
CUSTOMER P/N:		SCALE	NO
DESCRIPTION	HDMI 2.0V 19+1BC 26+28+26AWG	PAGE NO	1/1
		DATE	2019/11/23
APPROVAL		CHECKED	
		DRAWN	