

REV.	REVISED DESCRIPTION	DATE	CHECKED
A0	FIRST RELEASE	2019/12/18	

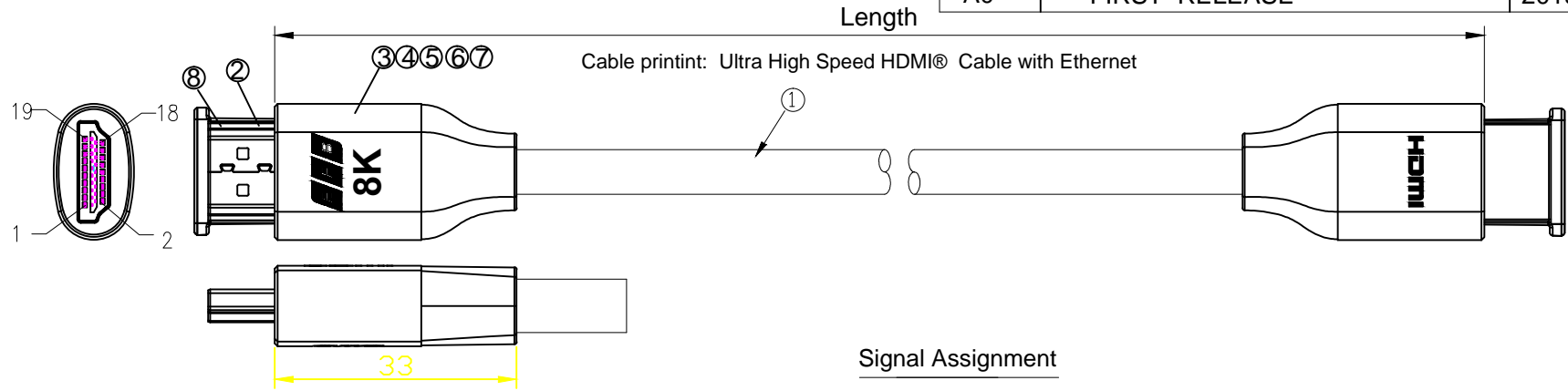

Remark:

- 100% Open/Short Test
- Conductive Resistance:10ohms MAX
- Insulation Resistance:5M ohm MIN.
- HI-POT:DC 300V/10MS.
- The product is CE/RoHS compliant/Reach.
- Resolution:8K@60Hz

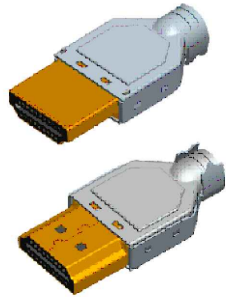

Signal Assignment

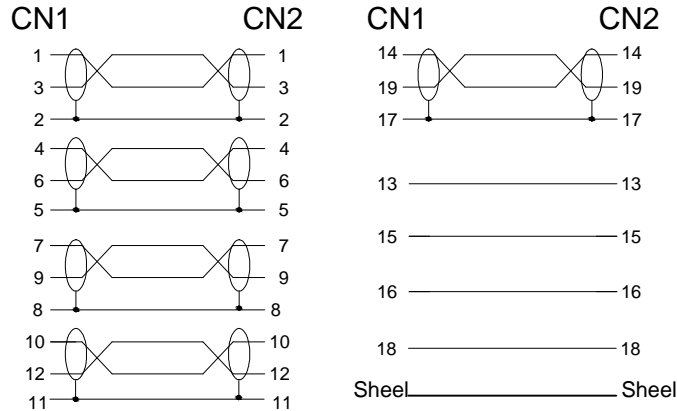

Remark:

- 100% Open/Short Test
- Conductive Resistance:10ohms MAX
- Insulation Resistance:5M ohm MIN.
- HI-POT:DC 300V/10MS.
- The product is RoHS compliant.
- Support 1080P/3D/8K@60Hz

Item NO.	Length(m)
K5440HQSW.1	1.0m
K5440HQSW.2	2.0m

ITEM	DESCRIPTIONS & SPECIFICATIONS	QTY	REMARK
⑧	HDMI Protective Cap, PE	2PCS	
⑦	Al shell	ZG-1726 Al shell, Gun black	2PCS
⑥	External Mold	Outer Mould 45P PVC, Black	
⑤	Copper Foil	Double sided conductor Copper Foil W5xL30MM	2PCS
④	Shielding Shell	Shielding Shell,tinplate	2PCS
③	Bracket	Bracket PA66	2PCS
②	Connector	HDMI A PLUG PIN, Gold-Plated	2PCS
①	Cable	30AWG 2.1V 30AWG(1/0.254BC x 1P + D1/0.254TC + AL-Foil + HM-Mylar) x 5C + 1/0.254BC x 4C + F + AL-foil + D1/0.254TC + 144/0.12AL, OD=6.5 Black PVC	

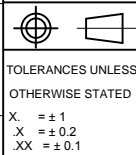

ERP NO.:		SAMPLE DWG NO:	
DOC No.:		REVISION	A0
CUSTOMER:		UNIT	mm
CUSTOMER P/N:		SCALE	NO
DESCRIPTION	HDMI2.1V 30AWG OD6.5mm 8K@60Hz with Can Shielding inside	PAGE NO	1/1
		DATE	2019/12/18
APPROVAL		CHECKED	
		DRAWN	