

---

# 10/100Base-Tx to 100Base-Fx Media Converter

## 1 GENERAL DESCRIPTION

The media converter transform the transmission media of Ethernet signal from CAT5 to optical fiber. it can extend the transmission distance to several kilometer or hundred kilometer.

Using media converter is a economical solution to achieve long distance transmission base on current status.

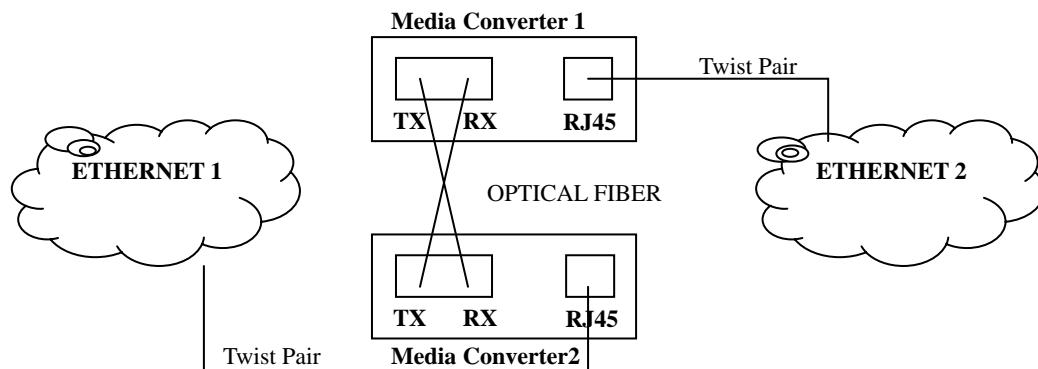

FIGURE 1.1 Media converter application

## 2 FEATURES

1. Built in a 2-port switch:
  - Pass all packets without address and CRC check (optional);
  - Supports modified cut-through frame forwarding for low latency;
  - Supports pure converter mode data forwarding for extreme low latency;
  - Supports flow control for full and half duplex operation;
  - Bandwidth control;
  - Forward 1600 bytes packet for management;
  - Optional forward fragments.
2. Supports 100Base-FX standard;
3. Built in 128Kb RAM for data buffer;
4. Supports auto MDI-MDIX function;
5. Supports link fault pass through function (LFP);
6. Supports for end fault function (optional);
7. LED display for link/activity, full/half, 10/100M
8. Support EEPROM configuration (optional);
9. the longest transmission distance reach 120 kilometers;

### 3 STANDARD

IEEE802.3 ETHERNET STANDARD

IEEE802.3u FAST ETHERNET STANDARD

### 4 PRODUCTS CLASSIFICATION & LEDS

1. ACCORDING TO OUTLINE:

200V/110V AC input power standalone media converter;

+5V DC input power standalone media converter;

Optional USB PORT or +5V DC input power standalone media converter;

media converter Card;

Rack System Chassis(2U);

2. ACCORDING TO QUANTITY of FIBER:

Single fiber bidirection media converter,

Dual fiber media converter;

3. ACCORDING TO TYPE OF FIBER:

Multimode media converter, Singlemode media converter;

4. +5V DC input power standalone media converter can be applied for 14 slots rack mounted chassis, media converter Card applied for 16 slots rack mounted chassis

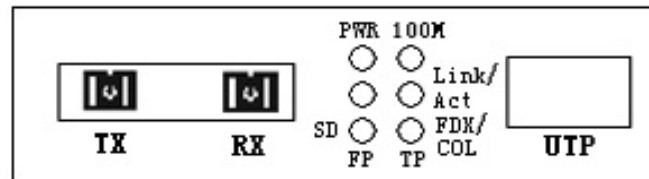

Table 1 : Front panel for dual fiber media converter

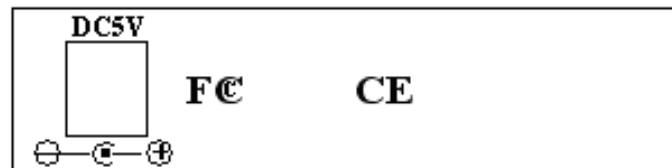
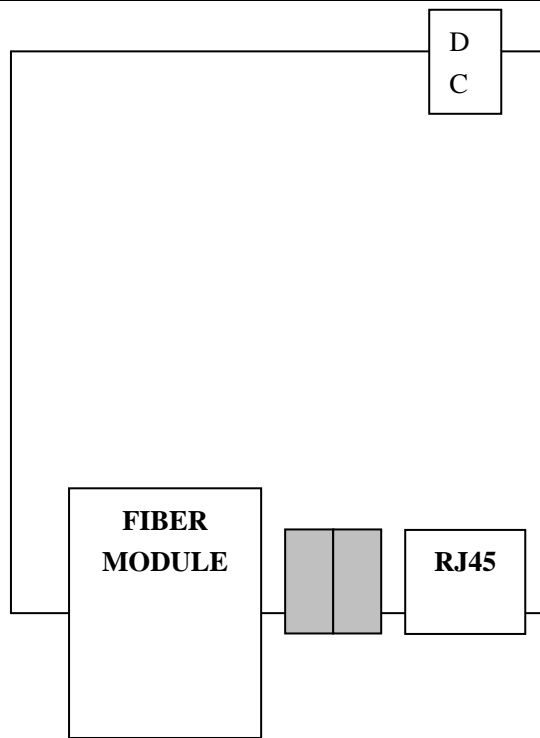

Table 2 : Back panel for single/dual fiber media converter



**FIGURE 3 Stand alone media converter outline**

## 5 LED FUNCTION DISCRIPTION

**TABLE 5.1 LED FUNCTION DISCRIPTION**

<b>LED</b>		<b>STATUS</b>
PWR	ON	POWER ON
	OFF	POWER OFF
FX-SD	ON	RECEIVER OPTICAL SIGNAL
	OFF	NO OPTICAL SIGNAL INPUT
FX-LINK/ACT	ON	LINKED ON FIBER PORT
	FLASH	ACTIVITY
	OFF	NOT LINKED
TX-SPD	ON	100M BASE-TX
	OFF	10M BASE-TX
TX-LINK/ACT	ON	LINKED ON UTP PORT
	FLASH	ACTIVITY
	OFF	NOT LINKED
TX-FDX/COL	ON	FULL DUPLEX
	OFF	HALF DUPLEX

## 6 PARAMETER

TABLE 6.1 PARAMETER

	10/100M multimode media converter	10/100M singlemode media converter
Cable	MM Fiber / Twist Pair	SM Fiber / Twist Pair
Transmission Type	10/100M FDX/HDX	10/100M FDX/HDX
MTBF	>3 years	>3 years
BER	<1E-8	<1E-8
Data Buffer	128Kb	128Kb
Power temperature variation	0. 2mw/°C	0. 2mw/°C
Input Power Range ( dBm)	0~-30	0~-40
Operate Temperature	0°C~70°C	0°C~70°C
Storage Temperature	-45°C~80°C	-45°C~80°C
I <sub>max</sub>	800mA	800mA
Power	2. 5w	2. 5w
EMC	FCC Part15	FCC Part15
Size	95×70×26mm (external power )	95×70×26mm (external power )
	140×110×30mm (internal power )	140×110×30mm (internal power )